

**VELTEKO**

**VERTICAL  
PACKAGING  
MACHINE**



**US**

**100**

CREATE & CLOSE PACKAGING LINE

# Custom product mixes

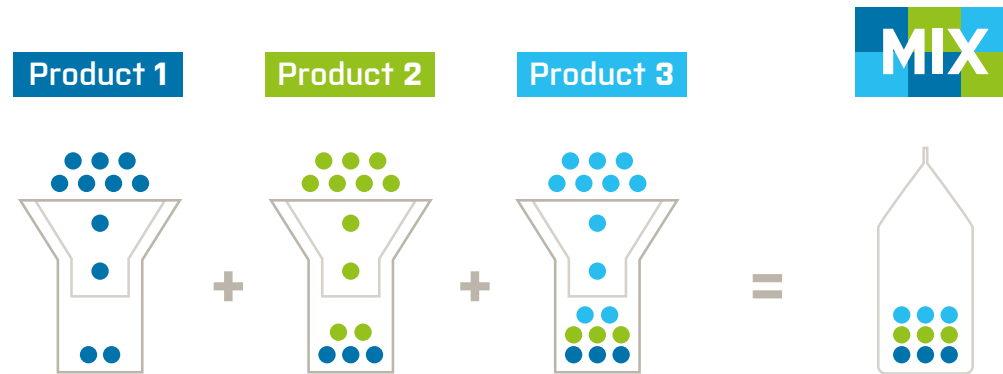

# Packages fragile products

- Low drop height of 360mm for gentle dosing and packaging of fragile products
- Nearly 0% product breakage
- Maintains the structure and quality of the packaged product

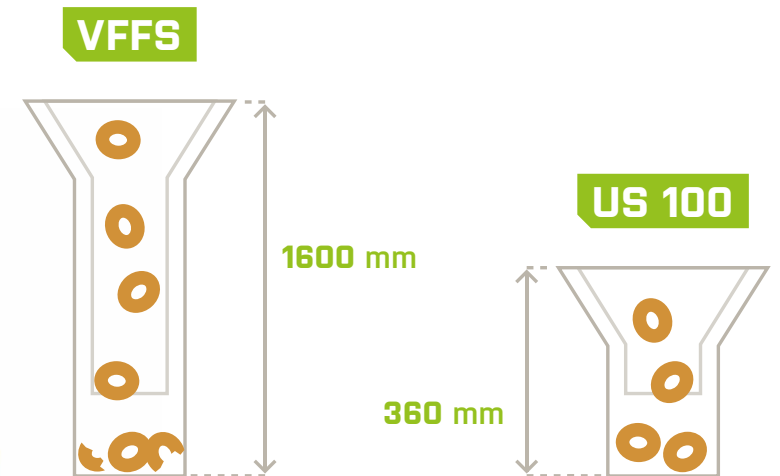

## More types of products in one bag

Multiple dosers on one machine allows you to create **your own product mix** in each package.

# 8 bag types on one machine

Flat bottom bag



Corner creased bag



Quad seal bag

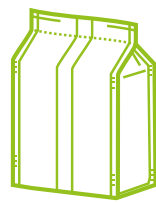

Brick bag

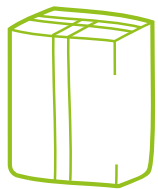

Corner creased brick bag

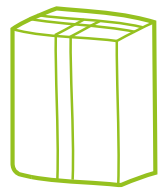

Quad seal brick bag

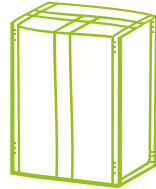

Pirouette Pouch



Expander

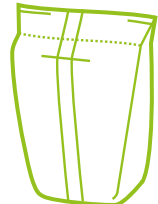

The modular design of the **US 100** allows you to create a wide range of solutions with **8 basic bag types**, including **Tin Tie** reclosing and many other types of modifications.

# Modifications that expand bag functions

## Top Seal Folding

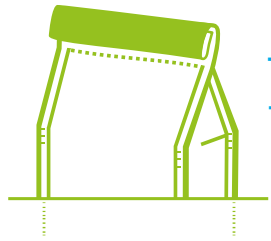

TOP 360  
+ HOTMELT

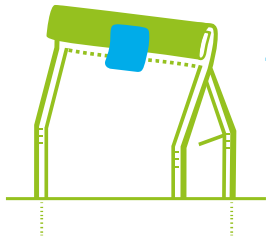

TOP 360  
+ LABEL

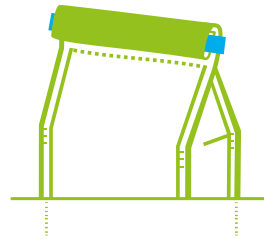

TOP 360  
+ TIN TIE



TOP 180  
+ HOTMELT

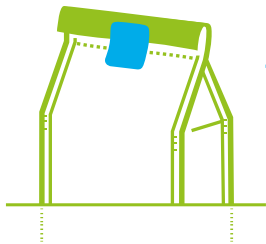

TOP 180  
+ LABEL

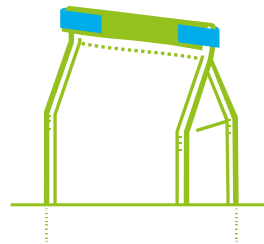

TOP 180  
+ TIN TIE

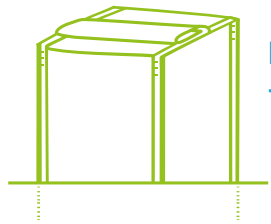

E 270  
+ HOTMELT

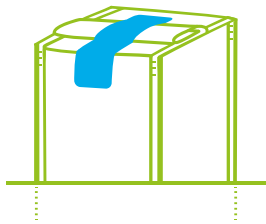

E 270  
+ LABEL

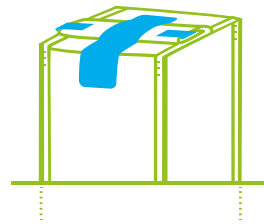

E 270  
+ TIN TIE  
+ LABEL

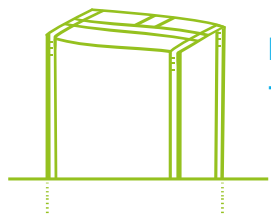

E 90  
+ HOTMELT

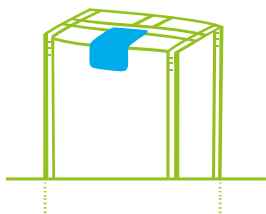

E 90  
+ LABEL





# Practical and functional solutions

## Label

The simplest reclosable bag. In addition, the label can have its own customized artwork.



## Tin Tie

Tin Tie is a proven reclosable bag suitable for a wide range of products. We especially recommend it for packaging tea and coffee.

## Euroslot

One of the most common bag modifications.



EASY PEEL



## Expander

In addition to a larger filling cross section, the bag also provides an increased advertising area on the front and back, and can be equipped with a variety of modifications.

# VELTEKO Philosophy

Provide customers around the world with a wide range of versatile and specialized vertical packaging solutions tailored to their individual needs.

## Advanced Engineering, Design and Construction

Extreme reliability and an extra long service life are a direct result of VELTEKO's cutting edge engineering and design, combined with precise manufacturing in the Czech Republic using the highest quality materials and branded components.

## We supply complete packaging systems

- Upstream and downstream systems
- Custom project engineering
- Technical and engineering support throughout the packaging system's life cycle

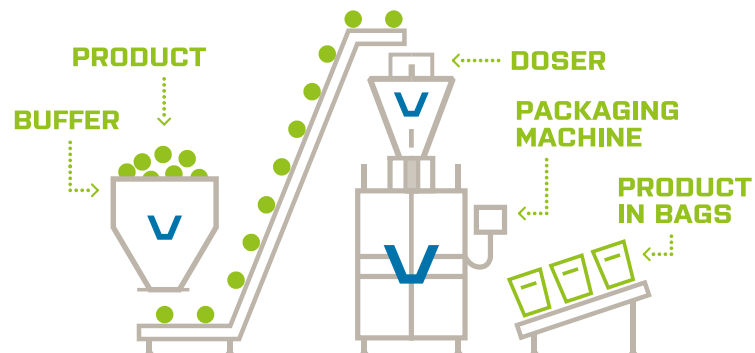

# Easy to maintain

- Monitoring of service intervals, depending on the type of machine operation.
- Extensive self-diagnostics and monitoring.
- Ability to set access rights to individual controls.
- Sensors with connectors for easy replacement.
- Interactive manual and spare parts catalogue for each specific machine configuration.
- Automatic check for pneumatic leaks.
- Support from VELTEKO's Service Center.

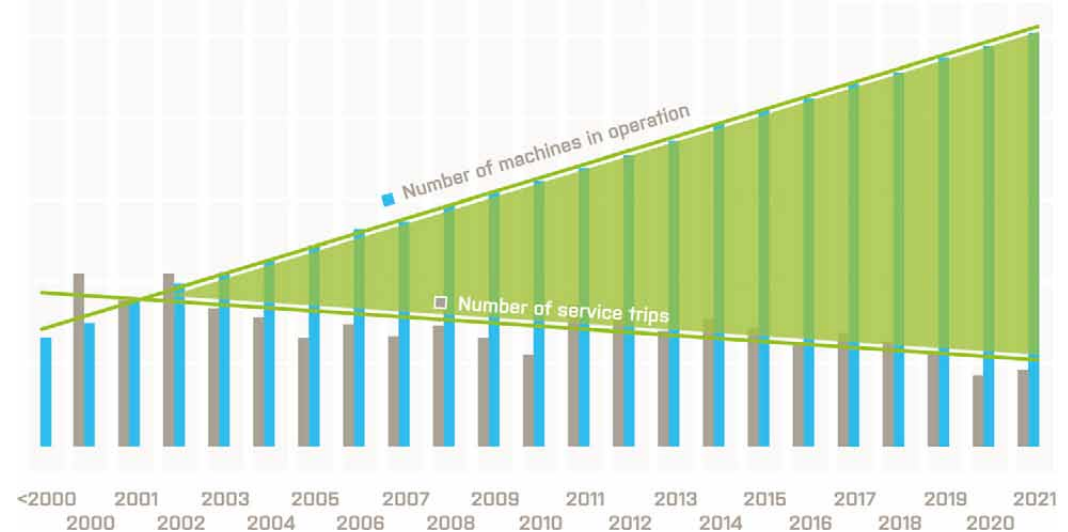

## MACHINE FEATURES

- Automatic film centering
- Friction/Vacuum pulling belts
- Registration mark sensor
- Mechanic/Pneumatic splicing table
- Robust stainless steel construction
- Self-diagnostics and troubleshooting

## HUMAN-MACHINE INTERFACE

- Full color touch screen
- Industrial PC
- Intuitive machine setup and on-screen guide
- User presets for machine setup

## DATASERVICE

- Online service support
- Online data management
- OPC dataservice available

## Technical parameters



Max. bag volume	3 liters
Min. dimension of bag bottom	60 x 40 mm
Max. dimension of bag bottom	140 x 100 mm
Max. bag height	330 mm
Max. film width	650 mm

## Basic dimensions of a standard US-100 packaging line

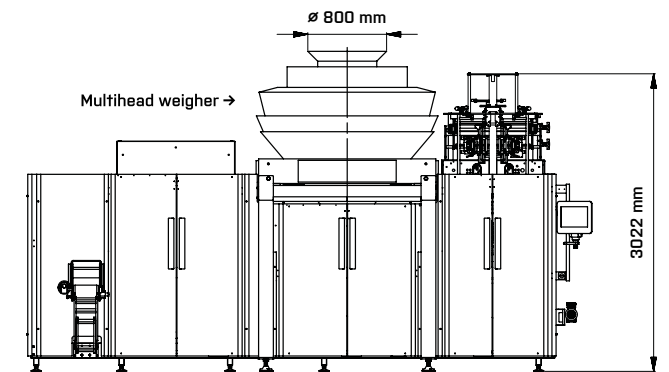

Full color touch screen with industrial PC

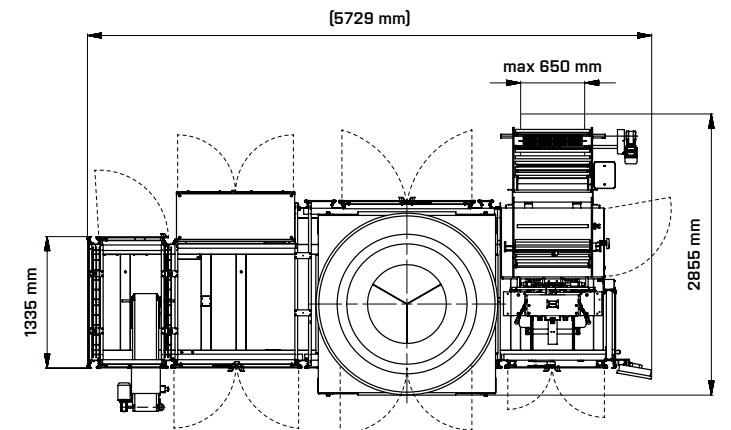

# Contacts

VELTEKO CZ s.r.o.  
K Borovickam 1716  
258 01 Vlasim  
Czech Republic  
Tel. +420 317 846 473  
velteko@velteko.cz

VELTEKO POLSKA Sp. z o. o.  
Ul. Sw. Michala 43  
61-119 Poznań  
Polska  
Tel. + 48 61 650 34 07  
velteko@velteko.pl

## GLOBAL SALES NETWORK

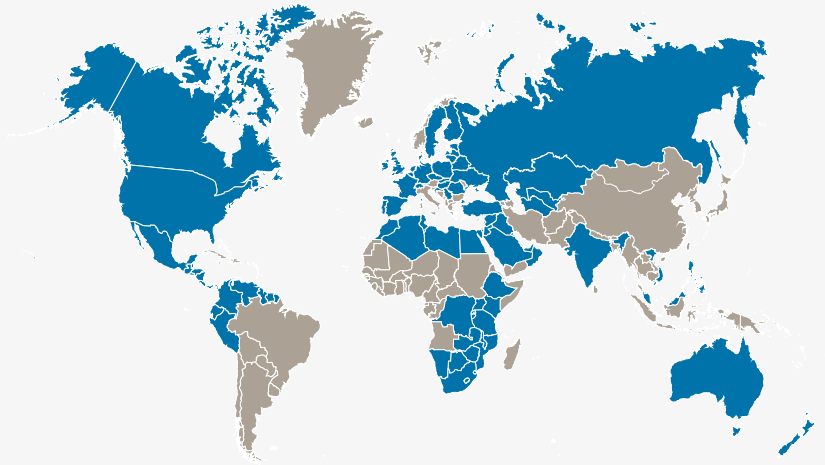

REGIONS COVERED BY VELTEKO DISTRIBUTORS

Your VELTEKO Distributor



[www.velteko.com](http://www.velteko.com)

The contents of this catalog are not an offer for a contract, a promise to conclude a contract nor any legal proceedings by VELTEKO s.r.o. regardless of its content or denominations. VELTEKO s.r.o. reserves the right to change the specifications of machines that are illustrated and described in this catalog. Photos of machines are for informational purposes only and may contain optional accessories. Please contact your local distributor to receive an offer that is tailored to your requirements.

## More machines from our portfolio

### SLIM-280

- Up to 200 bags/min
- Up to 400 bags/min with the twin version
- 820 mm wide - space-saving design for cost-effective production
- Strong/robust, hermetic seals
- Ideal for wide range of products from confectionery to snacks and fragile to liquids



### VERSATILE-280

- One machine for 10 bag types
- 15 modifications to extend bag functionality
- Maximum flexibility, your safe choice
- Extremely compact machine footprint
- Leading cost-effective DDYPACK production
- 200 bags/min maximum speed
- 5 - 45 min. changeover to different bag type



**VELTEKO – The vertical packaging machine experts**